

**L1KOM**  
contracting

ءانب لامعا

**L1KOM**



**Headquarters**

LIKOM Construction & Trading Co. Inc. | TURKEY

**Date of Establishment**

December 22<sup>nd</sup>, 2013

**Headquarters Address**

Umurbey Sok No 3 Filistin Cad GOP Çankaya Ankara

**Contact**

info@likom.com.tr

**Branch**

LIKOM Contracting L.L.C. | UAE

**Date of Establishment**

January 8<sup>th</sup>, 2019

**Branch Address**

Bayswater Bay by Omniyat Tower No1005 Business Bay Dubai

**Commercial License No**

8/1322

# ABOUT

LIKOM Construction & Trading Co. Inc. was founded in the year of 2013 in Ankara, Turkey by civil engineer Sarp Sagtekin. Since its establishment, LIKOM has worked on various projects from infrastructure to industrial structures together with its understanding of high level of service.

In January 2019, LIKOM CONTRACTING L.L.C. branch was established in Dubai, United Arab Emirates.

LIKOM constructs industrial buildings, facilities and housing with its young and dynamic structure, successful project management, high service quality and financial capability. With the projects that we undertake, we provide turn-key service including structural, architectural, electrical, mechanical construction, infrastructure as well as landscaping.

In the coming years, LIKOM aims to expand the business more by undertaking new challenges abroad.

*Sarp Sagtekin*  
General Manager

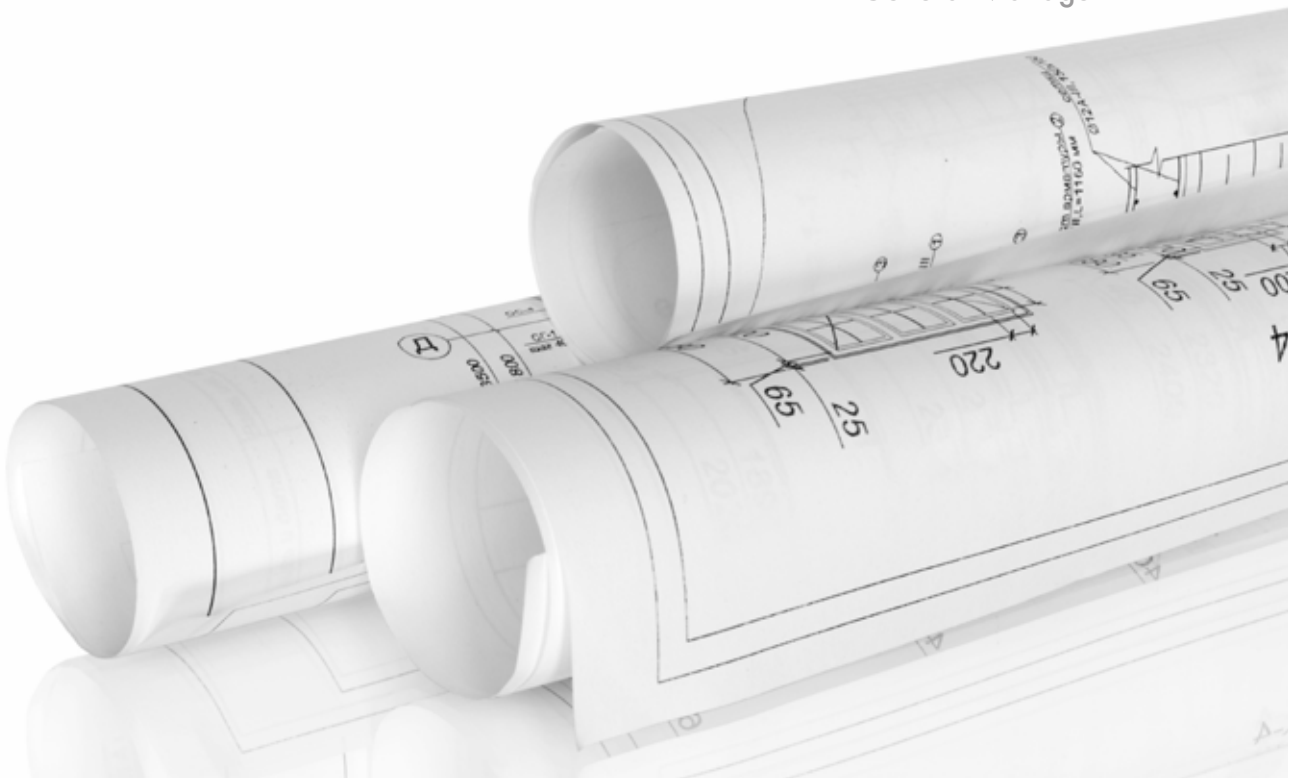

# MISSION

Our mission is to provide our clients with  
HIGH QUALITY SERVICE based on  
EFFICIENCY & MUTUAL TRUST.

# VISION

To become a well-recognised company  
known for QUALITY SERVICE,  
reliability & dynamism  
in the industry.

# CORE VALUES

## HONESTY

Integrity is one of the principles that will not be compromised by our company. We know that trust and communication which is key in increasing efficiency will be ensured with honesty.

## TEAM WORK + TRUST

We support our colleagues no matter what their position, age, gender and nationality is. As a team, we believe in the importance of trusting each other.

## QUALITY

We are committed to providing the highest quality service. We strive to achieve high performance in order to establish a smooth and long-term relationship with our partners and clients.

## OPENNESS + TRANSPARENCY

In order to maintain a transparent relationship with our clients, we openly share and discuss every issue. We are always open to innovations and suggestions for higher performance.

## RELIABILITY

We accept honesty and accuracy in all our commitments and partnerships.

**L1KOM**  
contracting

اناب لامع





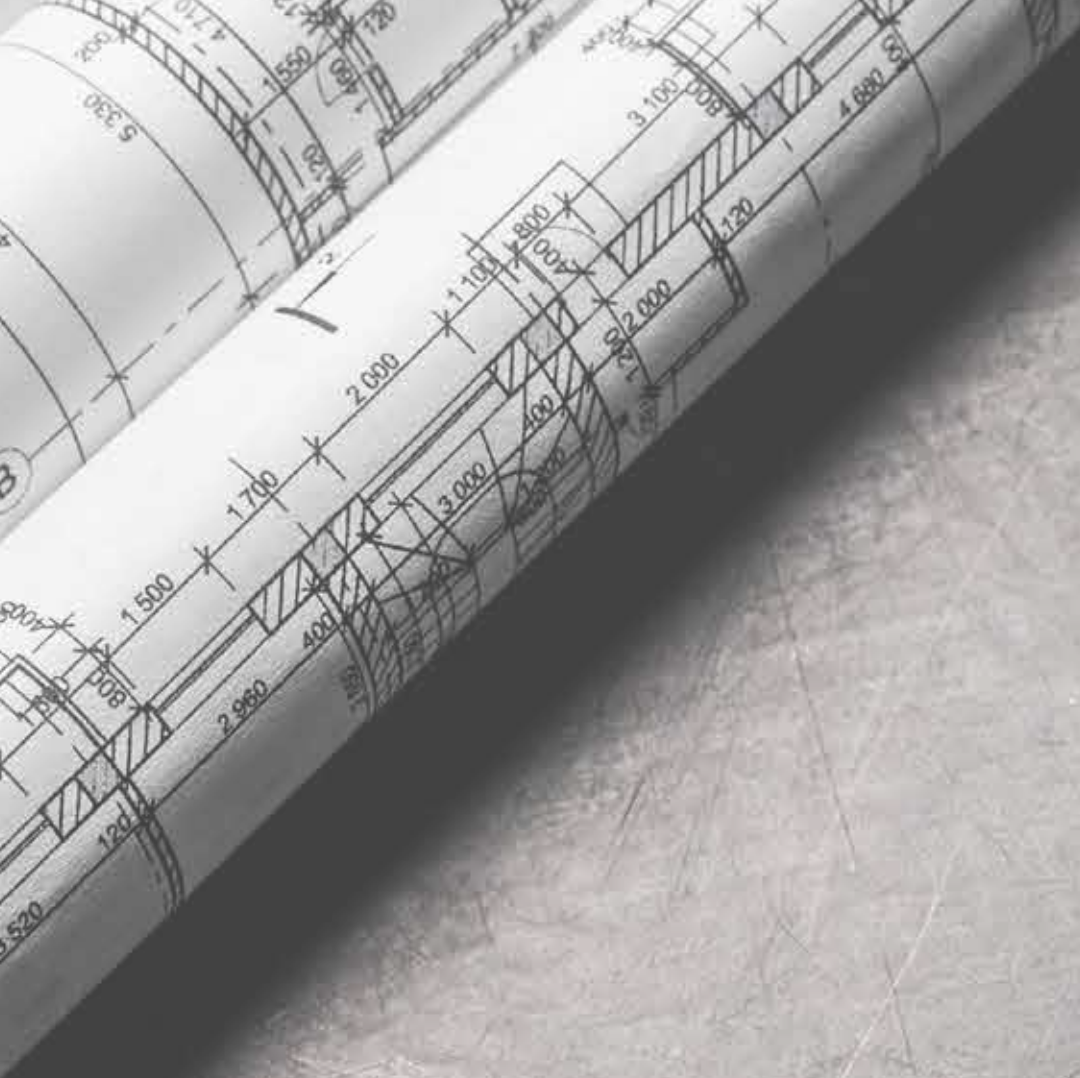

**> PROJECTS**

# CABLE CAR STATIONS

# 01

## Structural Work

TURKEY

<b>Employer</b>	Asteknik Construction and Trading Co. Inc.
<b>Location</b>	Yenimahalle - Ankara
<b>Construction Work</b>	Structural Construction
<b>Dates</b>	October 2013 - January 2014
<b>Contract Value</b>	1.300.000 USD

The structural construction of 3 cable car stations and 18 cable car foundations of Turkey's 1<sup>st</sup> cable car project to be used for public transportation was constructed in the capital city Ankara. The stations within the total 4.200 m<sup>2</sup> covered area with a ceiling height of 12 meters were completed 2 months before the deadline. In total, 320 tons of steel roof and 120 tons pedestrian bridge of 3 cable car stations were constructed by LIKOM.





# MODERN POULTRY FACILITY

# 02

**Structural + Architectural + Electrical + Mechanical Work**

*TURKEY*

**Employer** Iliz - Inova - Teknobi - Cansin Poultly Husbandry

**Location** Çerkez - Çankırı

**Construction Work** Turn-key

**Dates** October 2014 - December 2014

**Contract Value** 2.700.000 USD

4 modern poultry facility buildings in Çankırı Çerkeş district in Turkey and another 4 in Kurşunlu district within 17.000 m<sup>2</sup> closed area were constructed by us in 2 months time period. 34.000 m<sup>3</sup> excavation-filling, 560 tons steel roof, 17.000 m<sup>2</sup> sandwich panel works have been successfully completed by LIKOM.

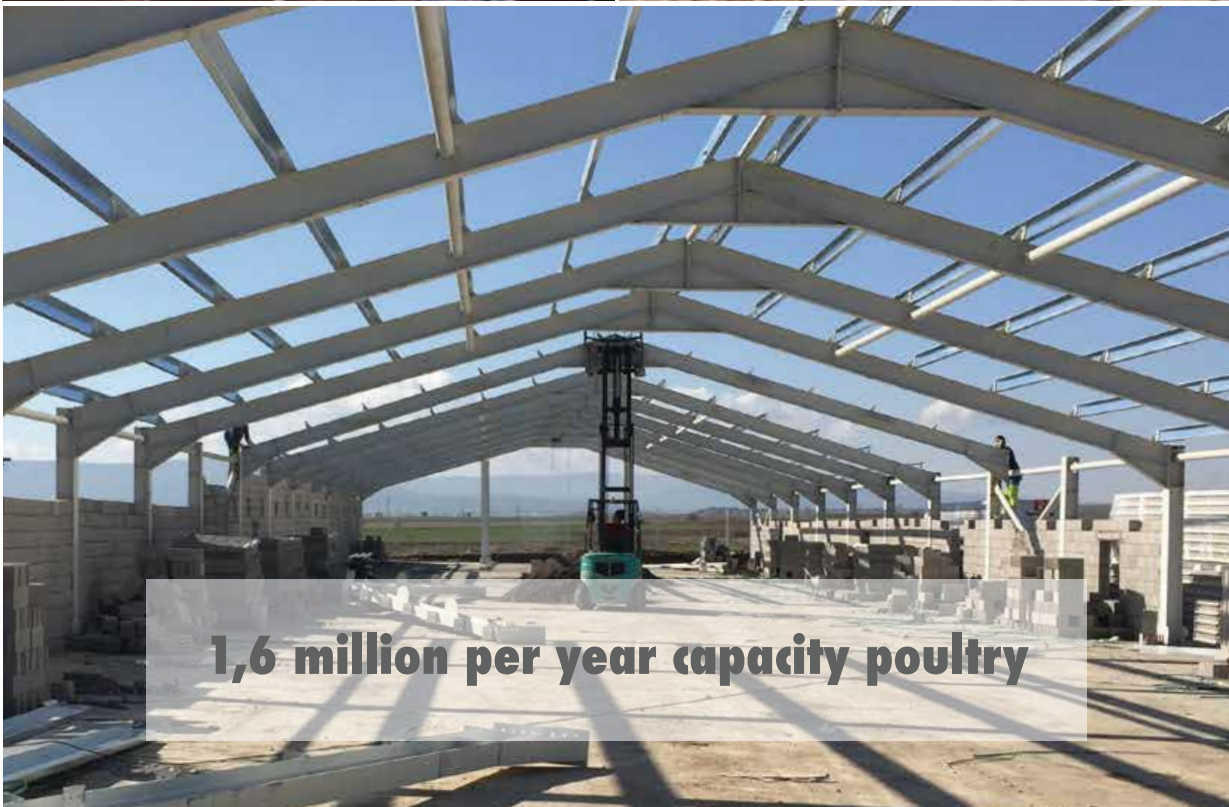

**1,6 million per year capacity poultry**

# OKSIJEN MALLS

# 03

## Structural Construction + Electrical & Mechanical Work

TURKEY

*Gebze - Orhangazi - İzmir Highway Project*

<b>Employer</b>	Highway Co. Inc.
<b>Location</b>	Yalova – Bursa – Orhangazi
<b>Construction Work</b>	Structural Construction
<b>Dates</b>	March 2015 - September 2015
<b>Contract Value</b>	4.242.680,65 USD
<b>Final Contract Value</b>	6.273.010,76 USD

GEBZE - ORHANGAZI - İZMİR HIGHWAY Construction Project on 14+800 km Altınova (O14 Mall) and 37+500 km Orhangazi (O37 Mall) was built within 13.500 m<sup>2</sup> construction area. The two projects included 13 reinforced concrete buildings with steel construction roof and was successfully completed as a turn-key. The project is one of the biggest infrastructure projects in Turkey and LIKOM is proud to be a part of it.







**One of the biggest infrastructure projects in Turkey**



# OKSIJEN MALL

## Architectural Construction

# 04

TURKEY

*Gebze - Orhangazi - İzmir Highway Project*

<b>Employer</b>	Highway Co. Inc.
<b>Location</b>	Yalova - Bursa - Orhangazi
<b>Construction Work</b>	Architectural Construction
<b>Dates</b>	July 2015 – May 2016
<b>Contract Value</b>	7.100.318 USD
<b>Final Contract Value</b>	13.110.400 USD

GEBZE - ORHANGAZI - İZMİR HIGHWAY Construction Project was built within 280.000 m<sup>2</sup> construction area. The project included the architectural, electrical, mechanical, infrastructural construction as well as the landscaping. The project was successfully completed as a turn-key.







# FNSS Defence Systems

# 05

## Curtain-wall Warehouse Silo Shelving System Construction

TURKEY

<b>Employer</b>	FNSS Defence Systems
<b>Location</b>	Gölbaşı - Ankara
<b>Construction Work</b>	Turn-key
<b>Dates</b>	August 2017 - February 2018
<b>Contract Value</b>	2.170.000 USD

Curtain Wall Silo Shelving System Warehouse Construction for FNSS Defence Systems was built within 1300 m<sup>2</sup> construction area with 18m ceiling height. The project included the construction of curtain-wall warehouse with silo shelving system construction along with steel construction carrier system and integrated automation system.







# FNSS Defence Systems Logistics Workshop Building

# 06

TURKEY

<b>Employer</b>	FNSS Defence Systems
<b>Location</b>	Gölbaşı - Ankara
<b>Construction Work</b>	Turn-key
<b>Date</b>	September - December 2018
<b>Contract Value</b>	553.000 USD

FNSS Defence Systems Logistics Workshop building construction was built in 500 m<sup>2</sup> area of construction with 13m ceiling height. The project included the construction of pre-fabricated reinforced concrete carcass, roof and facade panels as well as the electrical and mechanical works. The construction of the building was successfully completed in December 2018.





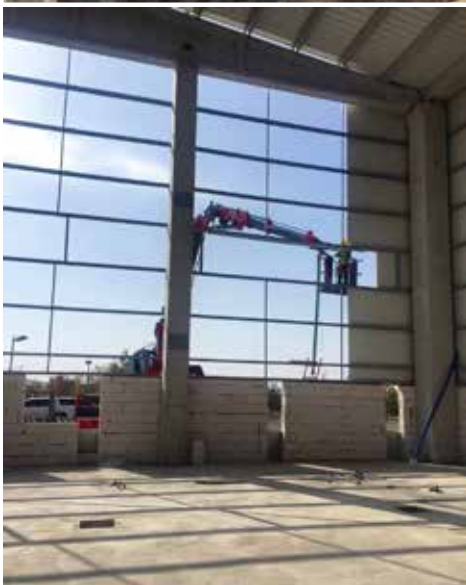

# FNSS Defence Systems

## Washing Building for Armored Vehicles

# 07

TURKEY

**Employer** FNSS Defence Systems

**Location** Gölbaşı - Ankara

**Construction Work** Turn-key

**Date** June 2018 - July 2018

**Contract Value** 225.816,06 USD

FNSS Defence Systems Washing Building for Armored Vehicles construction was built within 320 m<sup>2</sup> construction area with 12m ceiling height. The project included the construction of the steel carcass with roof and the facade panels. The project was successfully completed as a turn-key within the deadline.





*Ongoing Project*

# LIKOM HEADQUARTERS

# 08

## Building

TURKEY

<b>Employer</b>	Private
<b>Location</b>	GOP - Çankaya - ANKARA
<b>Construction Work</b>	Turn-key
<b>Date</b>	January 2020 - Ongoing
<b>Contract Value</b>	1.300.000 USD

LIKOM headquarters building in Ankara, Turkey is being renovated to attain a new look. While the exterior facade is being renewed, the interior repairs have also been rectified simultaneously.

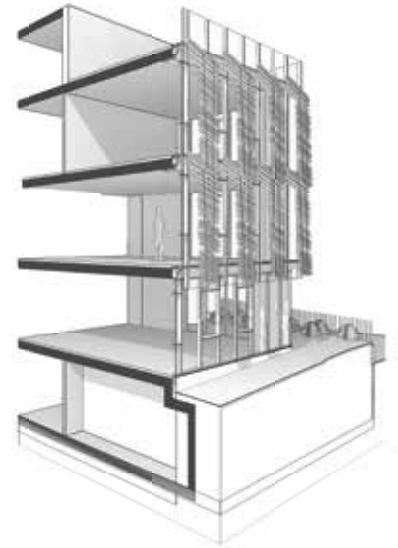

# VILLA in BODRUM

# 09

**Structural + Architectural + Electrical + Mechanical Work**

*TURKEY*

<b>Employer</b>	Private
<b>Location</b>	Türkbükü - Bodrum
<b>Construction Work</b>	Turn-key
<b>Date</b>	March 2017 - July 2018
<b>Contract Value</b>	553.000,23 USD







# G14, Golf Link Villas

## Dubai South Project

# 10

*Dubai, UAE*

<b>Employer</b>	EMAAR
<b>Main Contractor</b>	Nurol L.L.C.
<b>Location</b>	Dubai
<b>Construction Works</b>	Architectural and Structural Construction
<b>Dates</b>	January 2019 - December 2020
<b>Contract Value</b>	1.100.000 AED

Golf Link Villas is an epitome of urban living with three and four bedroom villas by the much renowned development entity Emaar Properties in the newly developed lively community of Dubai South. The steel fixing and shuttering works of the slab-on-grades, blockworks, interior and exterior plastering, tiling of wet and dry areas, suspended ceiling works and interlock installation of the villas have been conducted by LIKOM Contracting L.L.C.









Ongoing Project

# Creek Gate Plot

# 11

## A.32 Project

Dubai, UAE

<b>Employer</b>	EMAAR
<b>Main Contractor</b>	Nurol L.L.C.
<b>Location</b>	Dubai
<b>Construction Works</b>	Architectural Construction
<b>Dates</b>	June 2019 - Ongoing
<b>Contract Value</b>	500.000 AED

Creek Gate includes construction of 2 high-rise residential buildings Block A 2B+G+P+37F+R and Block B 2B+G+P+30+R standing over a common podium and two basement floors. The project houses 471 residential units. LIKOM Contracting L.L.C. has been contributing to the project with the tiling works of wet and dry areas including acoustic underlay works.



# The Cove Project

# 12

*Dubai, UAE*

<b>Employer</b>	EMAAR
<b>Main Contractor</b>	Nurol L.L.C.
<b>Location</b>	Dubai
<b>Construction Works</b>	Architectural Construction
<b>Dates</b>	May 2019 - Ongoing
<b>Contract Value</b>	1.500.000 AED

Three residential buildings consisting Block C - 2B+G+M+9+R, Block D - 2B+G+21+R and Block J - 2B+G+6+R in a common podium incorporating towers, car parking, amenity facilities, storage and circulation areas, hard and soft landscaping. LIKOM Contracting L.L.C. carries on tiling works of wet and dry areas including acoustic underlay works.



# Beach Vista Project

# 13

*Dubai, UAE*

<b>Employer</b>	EMAAR
<b>Main Contractor</b>	Nurol L.L.C.
<b>Location</b>	Dubai
<b>Construction Works</b>	Architectural Construction
<b>Dates</b>	December 2019 - Ongoing
<b>Contract Value</b>	2.000.000 AED

Beach Vista at Emaar Beachfront is a residential twin tower project featuring exclusive 1, 2, 3 & 4 bedroom apartments in Dubai. The project includes construction of 2 residential buildings with 33 and 26 floors. The tile fixing of wet and dry areas has been carrying on by Likom Contracting L.L.C.







